

## **Structured Analysis and Identification of the Operating Parameters of a Flexible Workshop**

**MLOUHI Yosra<sup>1</sup>, LAKHOUA Mohamed Najeh<sup>2</sup>, JABRI Imed<sup>1</sup>, BATTIKH Tahar<sup>1</sup>**

<sup>1</sup>Research Laboratory Information and Communication Technologies & Electrical Engineering, LATICE,

<sup>1</sup>National Superior School of Engineering, University of Tunis, Tunisia

Research Laboratory Smart Electricity & ICT, SEICT,

<sup>2</sup>National Engineering School of Carthage, University of Carthage, Tunisia

### **Abstract**

The requirements of the industry continue to increase and diverge. In a world where industrial mechatronic systems evolve from day to day, the intensity of these requirements influences the maximization of efficiency, the optimization of the safety of the working environment including human and the increase of the quality of services. This is why industrial computing is becoming a necessity for manufacturers and even researchers working on innovative and creative subjects. This paper deals with the analysis of a flexible manufacturing system. Firstly, the study of the system engineering then the composition of the studied system was presented. Second, a method of controlling and monitoring the Tri Festo station was proposed. The monitoring of the sorting station was essential to highlight its importance much more in practical areas. Finally, the last present conclusion and future work.

**KeyWords:** Mechatronic system, Flexible Manufacturing system, system engineering, supervision

## 1. Introduction

Towards the end of the 20th century, the world experienced an intellectual adventure based on discovering the complexity of the environment around us. Then, research is done to uncover anything that was considered extraordinary has been taken into account. A complexity that affects the cosmos, human societies, living organisms and especially systems designed by humans, such as businesses, technical, organizational, economic and social bills. The phenomenon of the globalization of trade, whether commercial, financial or cultural, has only accelerated this awareness of the complexity and accentuated its effects (Albers & al., 2013), (Askin & al., 1993).

All of this has prompted researchers from various fields to study this growing boom by creating new centers of interest. Therefore, today we are not only talking about increasingly complex systems but also about studies from different points of view.

The emergence of mechatronic systems is now considered a revolutionary discovery for the whole world. The use of these systems has spread rapidly and today affects almost all industrial sectors. Since systems engineering forms a primary foundation of mechatronics, it presents a challenge for industrial researchers who must have an aptitude to analyze and model systems in order to develop them. The main problem considered is then based on the complexity of these systems. Hence the existence of many physical couplings and many interfaces between the different components of a system. Research activity has been very active in the field for many years. The main idea is to improve the understanding of the observed phenomena, to master the design of these systems and, ultimately, to optimize their operation (Lakhoua & al., 2020), (El kalil & al., 2019).

Among the challenges to be taken up during the modeling of complex systems, we can cite the design and implementation of test devices dedicated to the studied objects, the determination of the correct complexity of the models developed to meet the needs posed and the positioning of the research strategy between academic research and industrial constraints (Gao & al., 2019), (Wertani & al., 2020).

An approach that brings together these different types of modeling is then required for it to be based on new representations of a real system, while taking into account instability, chaos, ambiguity, disorder, vagueness and paradox but which thus touch the creative side of development (Hardy & al., 2020), (Isermann & Rolf, 2000).

Computer engineering science then appeared to complete this approach and to implement developed computer tools with which human cooperates, intended for perception, observation, decision support and the management of dynamic industrial systems (Audrey, 2000) (Meyer, 2005).

In this context, computer-engineering science has as fields of investigation all the subjects or fields, which traditionally fall within the automatic control and establish concepts, specify models, develop methods and tools for the design and the realization of the command and control of these industrial processes. The programmable logic controller (PLC) (Gabriel & Mihalache, 2007) was used to carry out the formalism of the work steps based on the structuring of the data but also the communication steps. This study is divided into three parts; the first will be devoted to the study of mechatronic systems, through which we will present the field of mechatronics from different points of view namely mechanical, computer and electrical, and we will highlight the problematic considered through a case study detailed on the treated system and which presents a FESTO sorting station. The second part presents the study of the system engineering in which we will present the composition of the studied system. In the last part of this paper, we will propose a method of controlling and monitoring the Tri Festo station (Daniel, 2007).

## **2. Problem formulation**

Mechatronics is present in various fields and especially in the industrial field. Flexible manufacturing system are typical examples of a mechatronic system (Rohee & Riera, 2009) (Skhaf, 2001).

The flexibility manufacturing systems aims to create an industrial revolution, since a flexible manufacturing system comprises several numerically controlled machines integrating various stations which are connected to each other by a Fieldbus system. They are generally characterized by reprogrammable machines. Flexible systems are composed of complex and expensive machines, the number of which can be adjusted compared to other production systems. This allows a saving in cost and space of the order of 30% (Yadav & al., 2018) (Karoui & Lakhoua, 2019).

These systems are made up of equipment divided into four categories:

- Workstation
- Handling and transport systems.
- Storage systems
- Control and communication systems.

The figure 1 shows an example of type of mechatronic systems which is the flexible manufacturing system MPS 500 - FSM which will provide the axis of our study. It represents a multi-technological assembly owing to the merger and interactions between the different parts: mechanical, pneumatic, electrical, control and communication interfaces (Karoui & Lakhoua, 2019).

This manufacturing system has six stations linked together by a transport system, and presents a production chain organized as follows: a distribution station, a test station, a treatment station, an assembly station, a sorting and a storage station to manufacture cylinders with short strokes.

The process goes as follows:

- The cylinder body will be brought from the distribution station to the test station which will check the conformity of the cylinder dimension. This same station will then put the body on the conveyor pallet.
- The machining station retrieves the cylinder body from the conveyor, tests whether it has a hole or not, if it is not the machining station starts a drilling operation.

- To ensure that the machining is done in accordance with the specifications, a control with a camera is done in the next station
- In the next station, a 6-axis robotic arm assembles the cylinder, associating the rod, the spring and the cover
- The storage station collects the assembled parts if the sorting station is saturated.

*Figure 1: MPS 500 - FSM Station*

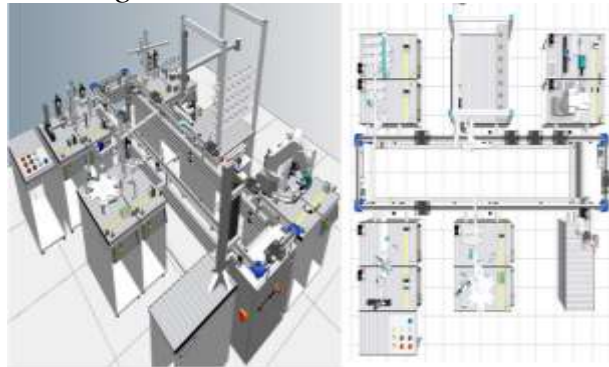

Finally, the sorting station will have the task of sorting the jacks according to their nature (the red plastic station, black plastic or metallic coating).

Each station, on its own, represents a mechatronic system that obeys the descriptions and definitions that we have presented previously. If we take the sorting station as an example. This station merges the different fields of electronics, mechanics and computing to form a typical mechatronics system.

It has sensors that provide information about the status of the system. The reports are sent to the control part, which consists of an industrial programmable logic controller, which will consider this information and give the appropriate orders to the actuators, depending on the program implemented in the PLC.

The operational part is essentially composed of pneumatic cylinders and a mini conveyor to bring the cylinders to their respective stocks.

The following figure describes the sorting station:

*Figure 2: Sorting station*

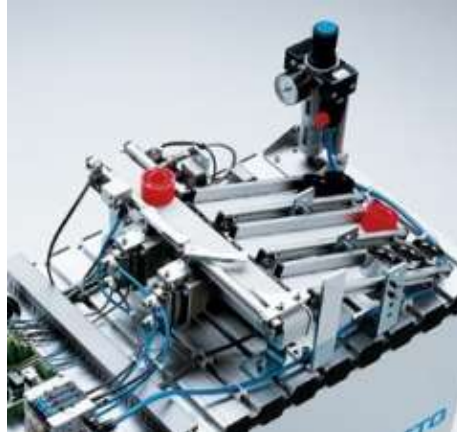

### 3. System engineering

Since mechatronic systems are multi-technology systems, the shift to system design is based on design methodologies [18], [19]. Among them there are:

- Structured analysis: it uses the data flow diagram which guarantees a top-down approach by refinement.
- Structured analysis and design technique (SADT): it represents the system in the form of actigrams or datagrams. This methodology can be refined because it is based on elementary boxes.
- Ward and Mellor: it is based on the use of two diagrams: DFD data flow and CFD control flow which complement each other to give execution semantics to the diagram.

These methods have limits in terms of their integration with other models or formalisms. The SADT method for example cannot cover the dynamic aspect of a mechatronic system. Hence, the link between the requirements and the methods mentioned is not adaptable for the system to be covered. Any trial implementation then depends on the publisher of the tool.

This is why, in seeking to guarantee the continuity and standardization of the design process, we use approaches that separate the processes and at the same time, implement standards that can be introduced into the different methods. Indeed, systems engineering processes can be summed up in three main approaches: abstract approaches, procedural approaches and analytical approaches (Barakat, 2017) (Karoui & al., 2020).

The first approaches are widely applied on various systems but they can be treated in different ways and generally do not have a big impact on the designer because they are difficult to apply. The second approaches are more concrete, they are more appropriate to practice and they are concerned with a very specific aspect related to the design project. As for the latter approaches, analytical approaches, they are used to improve design activities by describing some very specific aspects of a system and then its techniques, as well as the procedures and tools that use different representations. So these approaches are based on two essential parts, namely representation and procedures to achieve improvement goals (Lakhoua & Karoui, 2020).

The modeling makes it possible to study systems in several areas to achieve objectives well defined by specifications. A theory is necessary to define the model of the system which comprises characteristic quantities providing information on the components of the latter. A model then contains information on not only the geometry of the components and their masses but also on the relations which constitute it. Therefore, environmental modeling is necessary to define the spatial limits of the simulation of the initial state of the system. These relations are presented most of the time by mathematical equations (Karoui & Lakhoua, 2019).

## 4. Case study of controlling and monitoring

### 4.1 Supervision of the sorting station

There are several visions to determine the different tasks to be respected to supervise a mechatronic system. In this part, we will present the supervision only from a technical-functional point of view and from an applied view on high intensity automation systems. Detection and diagnosis of faults are two basic functions of an advanced industrial monitoring system. Their objective is to activate appropriate actions on a system depending on its state or mode of operation.

To better understand the functioning of the system already explained previously, we present in Fig.4 the GRAFCET from the control point of view which describes the sequence of the sorting of the parts. Indeed, GRAFCET always has the same structure but the most interesting thing is that that of the PC control part can be translated into PLC language after the precision of the inputs / outputs, references which will allow links between the PLC terminals and other system elements (sensors, pushbuttons, pre-actuators, etc.).

*Figure 3: GRAFCET of the sorting station operation*

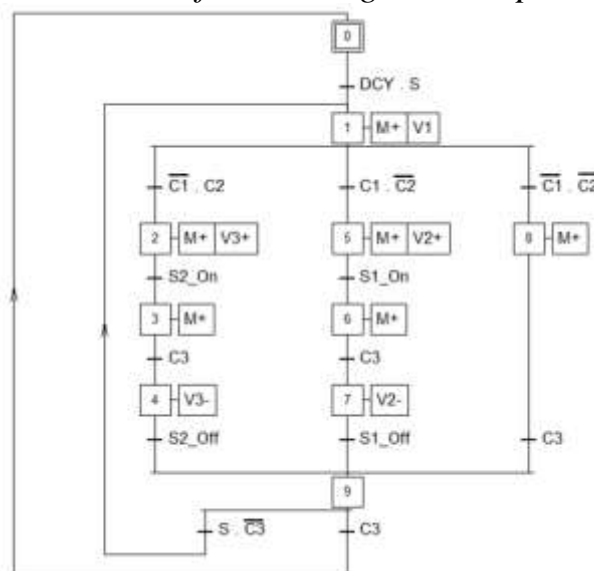



The following table presents the different components of the sorting station as well as their role in the operation of the station.

Table.1: Different component of the sorting station

Element	Role
M+ : Motor running	Convoyor belt running
M- : Motor stopped	Convoyor belt stopped
S : Capacitive sensor	Detection of the presence of a part at the entrance to the station
C1: Optical reflection sensor	Red or black part detection
C2 : Inductive sensor	Metal part detection
C3 : Photoelectric sensor	Detection of the part falling into one of the stocks
V1 : Pneumatic cylinder	stop the part
V2 : Separation cylinder 1	Separator to drop the red piece
V3: Separation cylinder 2	Separator to drop the metal part

Generally, flexible production systems include at least one PLC automation subsystem and another control and supervision subsystem.

For station monitoring, we will use TIA PORTAL V13 software. This software presents a Siemens work platform which has the role of enhancing automation solutions with an integrated

engineering system comprising software as SIMATIC STEP 7 V13 as well as SIMATIC WinCC V13 [TIA PORTAL].

The following flowchart shows the various stages of hardware and software configuration Fig.4.

*Fig.4: Hardware and software configuration flowchart*

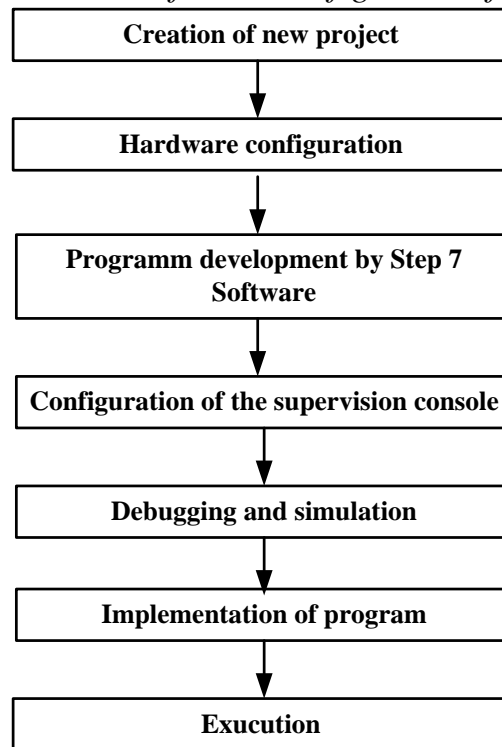

## 5. Conclusion

In this work, we studied a "FESTO sorting station" of a flexible manufacturing system allowing manufacturing single-acting cylinders. Then, we used the GRAFCET allowing the programming to guarantee the control and the monitoring of the sorting station. Finally, the last part was devoted to the surveillance of the station.

Uncovering the reality of a part of industrial computing has prompted us to find out how to use it to apply the methods used on complex systems that integrate dynamic components.

We therefore plan to find a solution to model the entire FESTO production line (the flexible workshop) which includes the different stations, based on the SysML method. Then, we will be interested in studying the exchange of energy flows between the different parts in order to supervise this data flow and test new supervision tools allowing to test the overall SysML model of the system.

### **References:**

- Albers, Albert and Christian Zingel, Challenges of model-based systems engineering: A study towards unified term understanding and the state of usage of SysML, Smart Product Engineering. Springer, Berlin, Heidelberg, 2013, 83-92.
- Askin, Ronald G., and Charles R., Standridge. Modeling and analysis of manufacturing systems. John Wiley & Sons Inc, 1993.
- Lakhoua, M.N., Ben Salem, J., Battikh, T., and Jabri, I., Review on Modeling and Design of Mechatronic Systems, International Journal of Mechatronics and Automation, vol.7, No.2, 2020.
- El-Khalil, Raed and Zainab Darwish, Flexible manufacturing systems performance in US automotive manufacturing plants: a case study, Production Planning & Control 30.1, 2019.
- Gao, Zhiwei, Sing Kiong Nguang and De-Xing Kong, Advances in Modelling, monitoring, and control for complex industrial systems, Complexity, 2019.
- Wertani, H., Ben Salem, J. and Lakhoua, M.N., Analysis and supervision of a smart grid system with a systemic tool, The Electricity Journal, Vol.33, Issue 6, July 2020.
- Hardy, Karim. Contribution à l'étude d'un modèle d'accident systémique, le cas du modèle STAMP : application et pistes d'amélioration. Diss. École Nationale Supérieure des Mines de Paris, 2010.
- Isermann, Rolf, Mechatronic systems: concepts and applications, Transactions of the Institute of Measurement and Control, 22.1: 29-55, 2000.

- Jardin, Audrey. Contribution à une méthodologie de dimensionnement des systèmes mécatroniques : analyse structurelle et couplage à l'optimisation dynamique, Diss. 2010
- Meyer, Y, Modélisation de systèmes complexes-Applications aux systèmes mécatroniques ,Doctoral dissertation, 2015.
- Mihalache, Alin Gabriel. Modélisation et évaluation de la fiabilité des systèmes mécatroniques : application sur système embarqué. Diss. 2007.
- Noyes, Daniel, and François Pérès, Analyse des systèmes-Sûreté de Fonctionnement, Techniques de l'ingénieur 2007.
- Rohee, Benoit, and Bernard Riera., Advanced supervisory control for manufacturing systems: from concepts to a separated monitoring system." IJISTA 6.3/4: 381-401, 2009.
- Skaf, Ahmad, Etude d'un système de supervision et de commande d'un procédé complexe comme élément de base d'une organisation distribuée comprenant des machines et des hommes. Diss. 2001.
- Yadav, Anupma, and Jayswal, S. C., Modelling of flexible manufacturing system: a review, International Journal of Production Research 56.7 2464-2487, 2018.
- Karoui, M. F. and Lakhoua, M.N., Methodology of Modeling and Supervision for Mechatronic Systems, Journal of Computer Science and Control Systems, Vol.12, N°1, 2019.
- Lakhoua, M.N. and Karoui, M.F., Monitoring of a Production System based on Functional and Dysfunctional Analysis, Journal of Computer Science and Control Systems, Vol.12, N°1, 2019.
- Gergely, E. I., Coroiu, Laura and Silaghi, Helga Maria, Dependability Analysis of PLC I/O Systems Used in Critical Industrial Applications, Studies in Computational Intelligence 417, 2013, pp. 201-217.
- Karoui, M.F., and Lakhoua, M.N., Information Organization of a Flexible Manufacturing based on System Modelling Approach, SSRG International Journal of Mobile Computing & Application (SSRG-IJMCA), Volume X Issue Y–Month 2020.

Barakat, S., Monitoring and Analysis of Microservices Performance”, Journal of Computer Science and Control Systems, Vol.10, N°1, May 2017.

Karoui, M.F., Aljouni, H., Wertani, H., Jemal M. and Lakhoua, M.N., Methodology of System Analysis and Monitoring of Wind Power Plant, 6th IEEE International Energy Conference (ENERGYCon), 28 Sept. - 1st Oct. 2020.

Lakhoua, M.N. and Karoui, M.F., Analysis and Supervision of Boiler in Thermal Power Plant, Journal of Computer Science and Control Systems, Vol.13, N°1, 2020.

Karoui, M.F. and Lakhoua, M.N., Methodology of Analysis, modeling and Supervision of SCADA Systems in Thermal Power Plants, APPEEC 2019, Xiamem, China.